

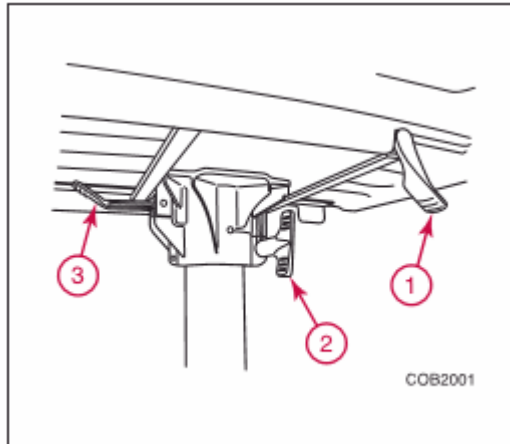

# Sliderule Racing Cobalt Seat Repair Kit

## How to Install

1. Remove Seat



Unscrew the #2 knob. Once loose, you will be able to lift the seat off of the pedestal.

2. Remove the seat slide assembly

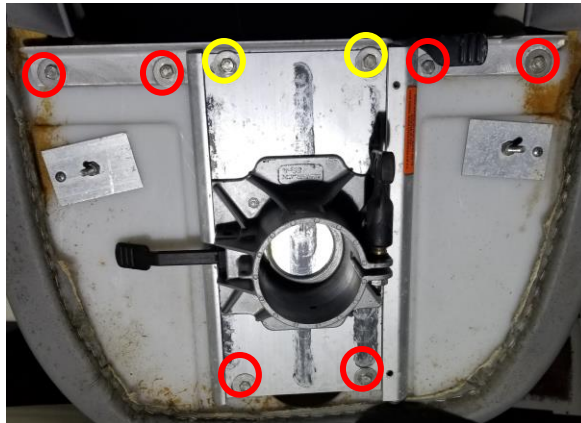

Remove the bolts circled in red holding the slide mechanism to the seat frame. You should not need to remove the bolts circled in yellow.

3. Remove the seat cushion

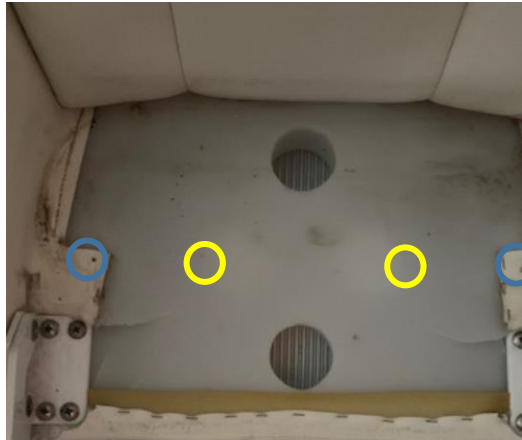

There are usually 2 philips head screws attaching the seat cushion to the seat assembly. In most seats these screws are out at the sides (blue circles) and in a few cases they are closer to the center (yellow circles). Note that this picture is from above – you will be removing the screws from the bottom of the seat.

4. Remove the bolster



With the cushion removed, you now have access to the 8 screws holding the 2 bolster hinges to the molded seat pan.



Place the plate on the seat pan. Make sure the counter sink side of the holes are facing UP (towards the cushion). Insert the assembly plugs into the large molded holes with the plastic part upwards. (plugs in photo below are older style)

5. Install the repair plate in place on the seat pan

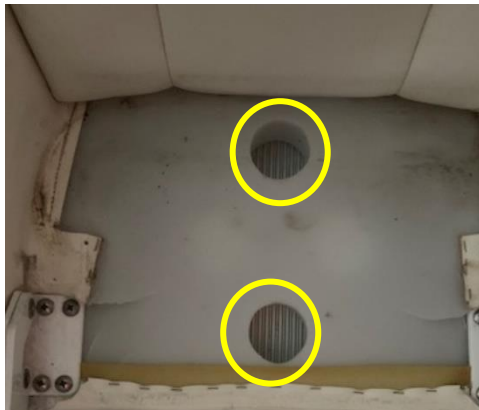

If necessary, use a fuel cap key while you tighten the  $\frac{1}{4}$ -20 stainless hex screws from above – most of the time the plug locks securely into the seat pan without the need for the fuel key.



Make sure that the plugs are fully bottomed in the hole and that the stainless disc is pressed against the plastic seat base.

<p>6. Reinstall the bolster hinges onto the repair plate</p>	 <p>Using the original screws, reinstall the bolster hinges to the repair plate.</p>
<p>7. Reinstall the seat cushion</p>	<p>Using the 2 new longer screws provided, reinstall the cushion to the seat.</p>
<p>8. Reinstall the slide frame assembly</p>	<p>Reinstall the sliding frame assembly to the seat base. You will find that the sliding frame contacts the stainless discs in the plugs. This is OK as long as the plugs are fully bottomed.</p>
<p>9. Reinstall the seat onto the pedestal</p>	<p>Drop the seat back onto the pedestal, snug up the locking screw and enjoy your repaired seat!</p>

### **Limited Lifetime Warranty**

The Sliderule Racing seat repair kit is manufactured from 316 stainless steel, aluminum and UHMW Polyethylene and is expected to have a very long life. But, sometimes stuff happens! As long as I am in business, I will repair or replace (at our discretion) any kits shown to have manufacturing or material defects.

### **What is *not* covered**

- Return shipping to Sliderule Racing
- Anything other than the kit itself